



**SOALAN PRAKTIS BESTARI**  
**PROJEK JAWAB UNTUK JAYA (JUJ) 2024**



**SIJIL PELAJARAN MALAYSIA**

**4531/1**

**FIZIK**

**Kertas 1 – Set 2**

1¼ jam

Satu jam lima belas minit

---

**JANGAN BUKA KERTAS SOALAN INI SEHINGGA DIBERITAHU**

1. *Kertas soalan ini adalah dalam dwibahasa.*
2. *Calon dikehendaki membaca maklumat di halaman bawah.*

**MAKLUMAT UNTUK CALON**

1. *Kertas soalan ini mengandungi 40 soalan.*
2. *Jawab **semua** soalan.*
3. *Jawab setiap soalan dengan menghitamkan ruangan yang betul pada kertas jawapan.*
4. *Hitamkan **satu** ruangan sahaja bagi setiap soalan.*
5. *Sekiranya anda hendak menukar jawapan, padamkan tanda yang telah dibuat. Kemudian hitamkan jawapan yang baru.*
6. *Rajah yang mengiringi soalan tidak dilukiskan mengikut skala kecuali dinyatakan.*
7. *Anda dibenarkan menggunakan kalkulator saintifik yang tidak boleh diprogramkan.*
8. *Satu senarai rumus disediakan di halaman 2-3.*

Rumus-rumus berikut boleh membantu anda menjawab soalan. Simbol-simbol yang diberikan adalah biasa digunakan.

**DAYA DAN GERAKAN I**  
**FORCE AND MOTION I**

- 1  $v = u + at$
- 2  $s = \frac{1}{2}(u + v)t$
- 3  $s = ut + \frac{1}{2}at^2$
- 4  $v^2 = u^2 + 2as$
- 5 Momentum =  $mv$
- 6  $F = ma$

**KEGRAVITIAN**  
**GRAVITATION**

- 1  $F = \frac{Gm_1 m_2}{r^2}$
- 2  $g = \frac{GM}{r^2}$
- 3  $F = \frac{mv^2}{r}$
- 4  $a = \frac{v^2}{r}$
- 5  $v = \frac{2\pi r}{T}$
- 6  $\frac{T_1^2}{r_1^3} = \frac{T_2^2}{r_2^3}$
- 7  $v = \sqrt{\frac{GM}{r}}$
- 8  $u = -\frac{GMm}{r}$
- 9  $v = \sqrt{\frac{2GM}{r}}$
- 10  $g = 9.81 \text{ m s}^{-2} @ 9.81 \text{ N kg}^{-1}$
- 11  $G = 6.67 \times 10^{-11} \text{ N m}^2 \text{ kg}^{-2}$

**HABA**  
**HEAT**

- 1  $Q = mc\Delta\theta$
- 2  $Q = m\ell$
- 3  $Q = Pt$
- 4  $P_1V_1 = P_2V_2$
- 5  $\frac{V_1}{T_1} = \frac{V_2}{T_2}$
- 6  $\frac{P_1}{T_1} = \frac{P_2}{T_2}$

**GELOMBANG**  
**WAVES**

- 1  $v = f\lambda$
- 2  $\lambda = \frac{ax}{D}$

**CAHAYA DAN OPTIK**  
**LIGHT AND OPTICS**

- 1  $n = \frac{c}{v}$
- 2  $n = \frac{1}{\sin c}$
- 3  $n = \frac{H}{h}$
- 4  $\frac{1}{f} = \frac{1}{u} + \frac{1}{v}$
- 5  $n_1 \sin \theta_1 = n_2 \sin \theta_2$
- 6 Pembesaran linear,  $m = \frac{h_i}{h_o} = \frac{v}{u}$   
  
*Linear magnification,  $m = \frac{h_i}{h_o} = \frac{v}{u}$*

**DAYA DAN GERAKAN II**  
**FORCE AND MOTION II**

- 1  $F = kx$
- 2  $E_p = \frac{1}{2}Fx = \frac{1}{2}kx^2$

**TEKANAN**  
**PRESSURE**

- 1  $P = \frac{F}{A}$
- 2  $P = h\rho g$
- 3  $\rho = \frac{m}{v}$

**ELEKTRIK**  
**ELECTRICITY**

- 1  $E = \frac{F}{q}$
- 2  $I = \frac{Q}{t}$
- 3  $V = \frac{E}{Q}$
- 4  $V = IR$
- 5  $R = \frac{\rho l}{A}$
- 6  $\mathcal{E} = V + Ir$
- 7  $P = VI$
- 8  $P = \frac{E}{t}$
- 9  $E = \frac{V}{d}$

**ELEKTROMAGNET**  
**ELECTROMAGNETISM**

- 1  $\frac{V_S}{V_P} = \frac{N_S}{N_P}$
- 2  $\eta = \frac{\text{Kuasa output}}{\text{Kuasa input}} \times 100\%$   
 $\eta = \frac{\text{Output power}}{\text{Input power}} \times 100\%$

**ELEKTRONIK**  
**ELECTRONICS**

- 1 Tenaga keupayaan elektrik,  $E = eV$   
*Electrical potential energy,  $E = eV$*
- 2 Tenaga kinetik maksimum,  $E_k = \frac{1}{2}mv^2$   
*Maximum kinetic energy,  $E_k = \frac{1}{2}mv^2$*
- 3  $\beta = \frac{I_C}{I_B}$

**FIZIK NUKLEAR**  
**NUCLEAR PHYSICS**

- 1  $N = \left(\frac{1}{2}\right)^n N_0$
- 2  $E = mc^2$
- 3  $c = 3.0 \times 10^8 \text{ m s}^{-1}$
- 4 1 u.j.a =  $1.66 \times 10^{-27} \text{ kg}$   
1 amu =  $1.66 \times 10^{-27} \text{ kg}$

**FIZIK KUANTUM**  
**QUANTUM PHYSICS**

- 1  $E = hf$
- 2  $f = \frac{c}{\lambda}$
- 3  $\lambda = \frac{h}{p}$
- 4  $\lambda = \frac{h}{mv}$
- 5  $E = \frac{hc}{\lambda}$
- 6  $P = nhf$
- 7  $hf = W + \frac{1}{2}mv^2$
- 8  $W = hf_0$
- 9  $h = 6.63 \times 10^{-34} \text{ J s}$

- 1 Rajah 1 menunjukkan susunan radas untuk mengkaji Hukum Charles.  
Diagram 1 shows the arrangement of apparatus used to study the Charles' Law.

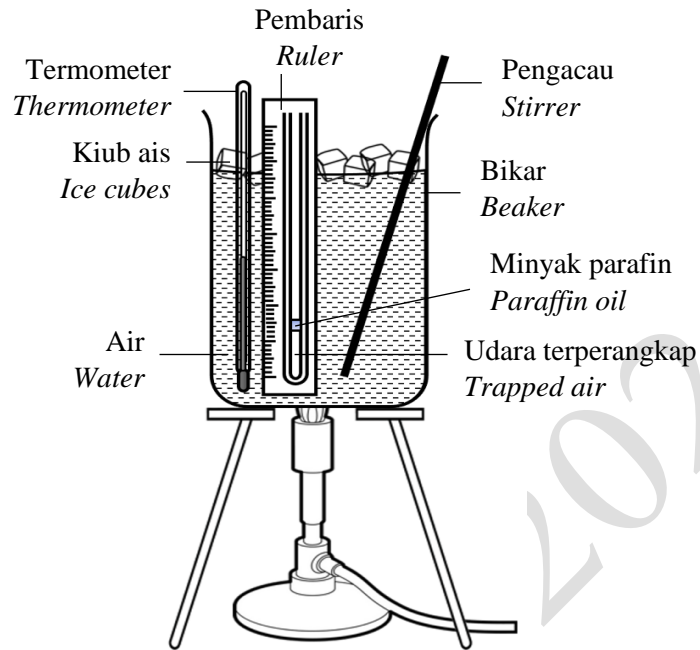

Rajah 1  
Diagram 1

Pasangan yang manakah adalah betul mengenai hubungan dan bentuk graf?  
Which of the following pairs is correct about the relationship and shape of the graph?

	Hubungan Relationship	Bentuk graf Shape of the graph
<b>A</b>	$V$ berkadar terus dengan $\frac{1}{T}$ $V$ is directly proportional to $\frac{1}{T}$	
<b>B</b>	$V$ berkadar terus dengan $T$ $V$ is directly proportional to $T$	
<b>C</b>	$V$ berkadar songsang dengan $T$ $V$ is inversely proportional to $T$	

- 2 Rajah 2 menunjukkan keratan pita detik yang telah dipotong dan dilekat secara sebelah menyebelah.

*Diagram 2 shows the ticker tape strips which are cut and attached side by side.*

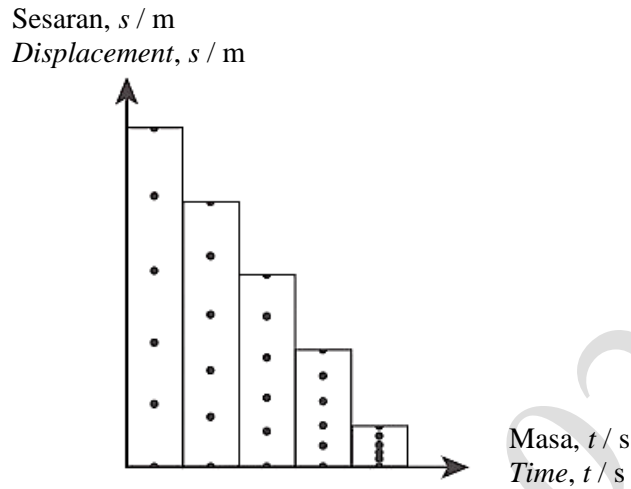

Rajah 2  
Diagram 2

Apakah jenis gerakan tersebut?  
*What is the type of motion?*

- A Halaju seragam  
*Uniform velocity*
- B Halaju bertambah  
*Increasing velocity*
- C Halaju tidak seragam  
*Non-uniform velocity*
- D Halaju berkurang secara seragam  
*Velocity decreases uniformly*
- 3 Antara berikut, situasi yang manakah menunjukkan konsep daya impuls?  
*Which of the following situation shows the concept of impulsive force?*

A



C



B



D



- 4 Rajah 3 menunjukkan graf sesaran,  $s$  melawan masa,  $t$  bagi suatu objek yang bergerak.  
 Diagram 3 shows a graph of displacement,  $s$  against time,  $t$  for a moving object.

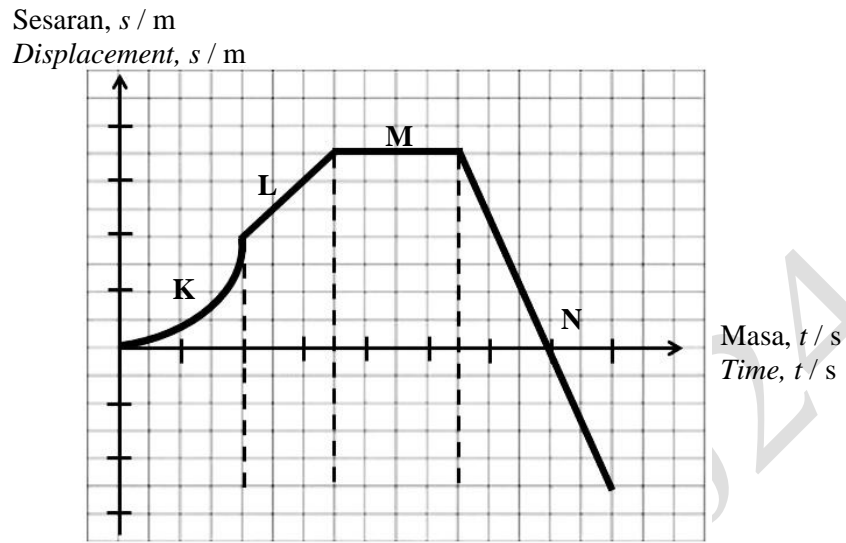

Rajah 3  
 Diagram 3

Graf halaju-masa manakah yang menerangkan pergerakan objek pada Rajah 3?  
 Which velocity-time graph describes the motion of object in Diagram 3?

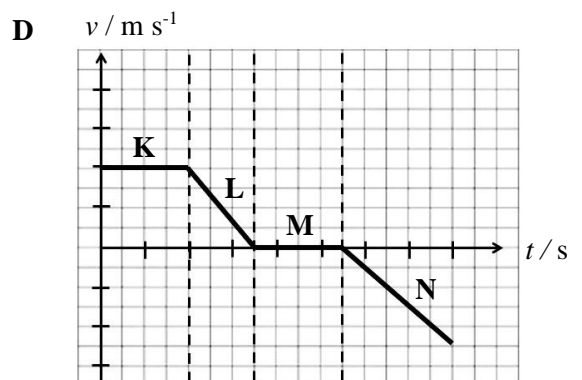
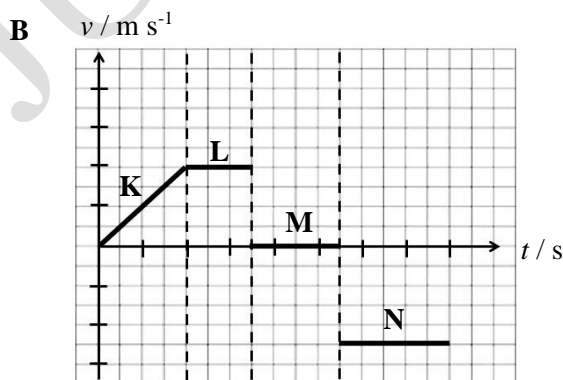
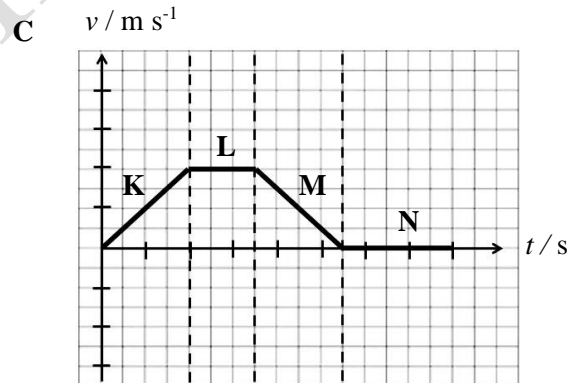
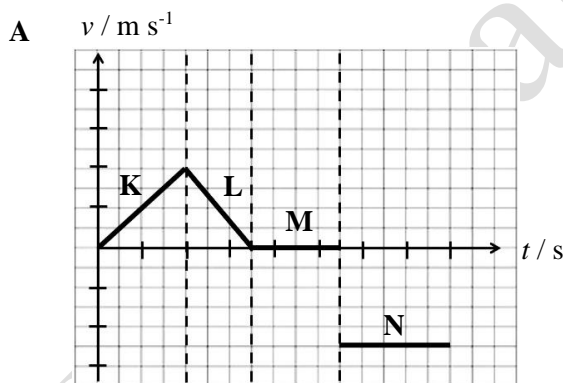

- 5 Rajah 4 menunjukkan sebatang penukul getah dan sebiji kentang yang dicucuk dengan pisau.  
*Diagram 4 shows a rubber hammer and potato being poked with a knife.*

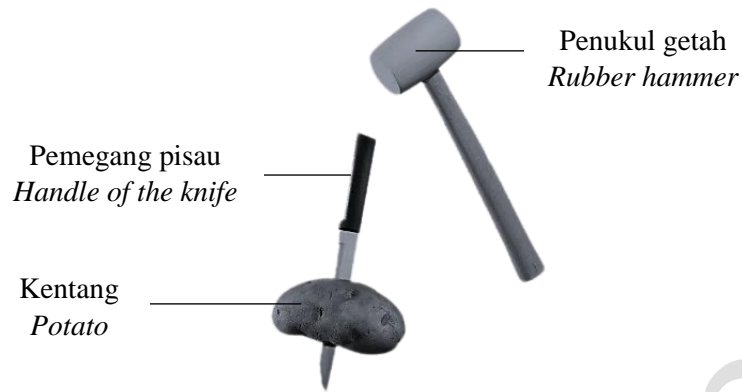

Rajah 4  
*Diagram 4*

Apabila penukul getah diketuk pada pemegang pisau, didapati kedudukan kentang tersebut berubah. Terangkan pemerhatian yang berlaku.

*When the rubber hammer is hit on the handle of the knife, it is found that the position of the potato changed. Explain the observation that occurred.*

- A Kentang bergerak ke atas disebabkan oleh inersia  
*The potato moves up due to inertia*
- B Kentang bergerak ke bawah disebabkan oleh graviti  
*The potato moves down due to gravity*
- C Kentang bergerak ke bawah disebabkan oleh tekanan yang dikenakan semasa mengetuk pemegang pisau  
*The potato moves down due to the pressure applied when hitting the handle of the knife*
- D Kentang bergerak ke atas disebabkan oleh daya impuls dikenakan semasa mengetuk pemegang pisau  
*The potato moves up due to the impulse force exerted when hitting the handle of the knife*
- 6 Rajah 5 menunjukkan seorang angkasawan sedang melompat di permukaan bulan.  
*Diagram 5 shows an astronaut is jumping at the moon's surface.*



Permukaan bulan  
*Moon's surface*

Rajah 5  
*Diagram 5*

Terangkan perubahan ketinggian lompatan jika angkasawan tersebut berada di Bumi.  
*Explain the change in jump height if the astronaut were on the Earth.*

- A Ketinggian berkurang  
*Height decreases*
- B Ketinggian bertambah  
*Height increases*
- C Ketinggian tidak berubah  
*Height unchanged*

- 7 Rajah 6 menunjukkan lintasan D dan lintasan E bagi objek X yang bergerak yang dilancarkan pada satu laju linear,  $v$ .  
*Diagram 6 shows the trajectory D and trajectory E of a moving object X launched at a linear velocity,  $v$ .*

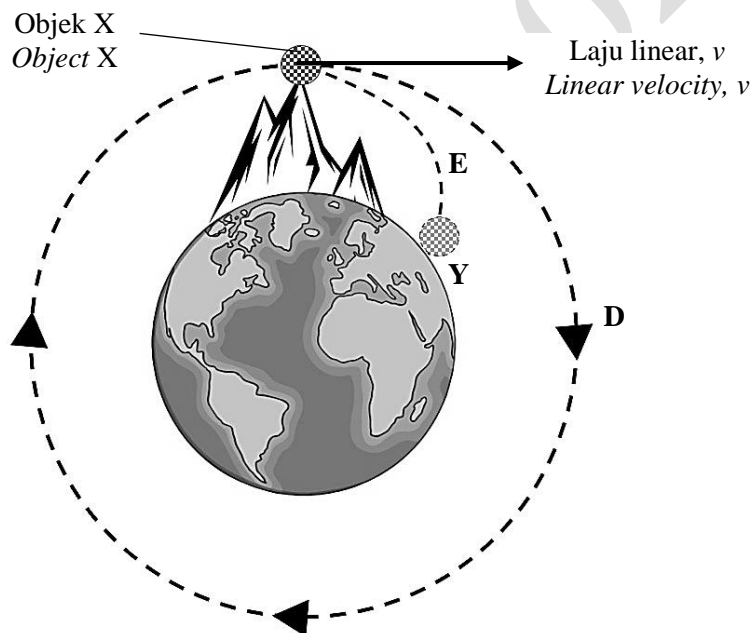

Rajah 6  
 Diagram 6

Antara berikut, pernyataan manakah adalah benar mengenai laju linear objek X?  
*Which of the following statements is true about the linear velocity of object X?*

- A Objek X yang melalui lintasan D mempunyai laju linear yang rendah  
*Object X that passes through the trajectory D has a low linear velocity*
- B Objek X yang melalui lintasan E mempunyai laju linear yang tinggi  
*Object X that passes through the trajectory E has a high linear velocity*
- C Objek X mengalami jatuh bebas dengan pergerakan pada lintasan D pada halaju linear yang tinggi  
*Object X experiences free fall with a motion on trajectory D at a high linear velocity*
- D Objek X mengalami jatuh bebas dengan laju linear yang rendah dan tiba di Bumi di Y kerana daya memusat bertindak ke atasnya  
*Object X experiences free fall with a low linear velocity and arrives at Earth at Y because of the centripetal force acting on it*



- 8 Pernyataan berikut merupakan satu hukum yang menghuraikan pergerakan planet mengelilingi Matahari.  
*The following statement is a law that describes the movement of the planet around the Sun.*

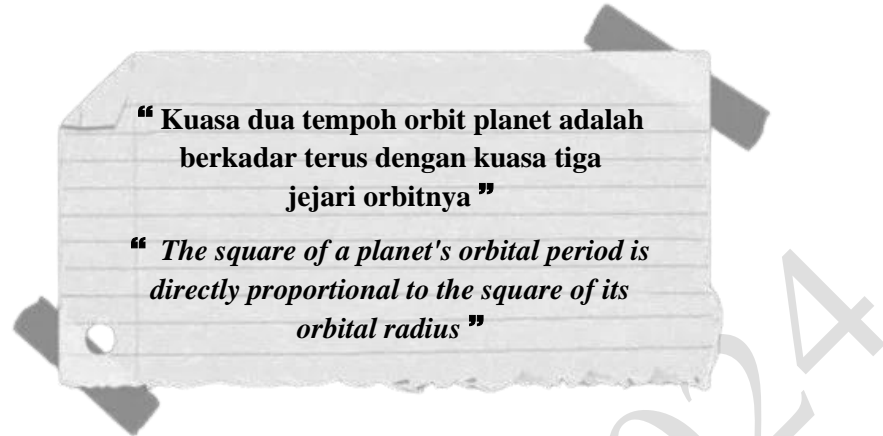

Apakah hukum yang terlibat?  
*What is the law involved?*

- |   |  |
|---|--|
| A Hukum Kepler Pertama<br><i>Kepler's First Law</i> | C Hukum Kepler Ketiga<br><i>Kepler's Third Law</i>                                 |
| B Hukum Kepler Kedua<br><i>Kepler's Second Law</i>  | D Hukum Kegravitian Semesta Newton<br><i>Newton's Universal Law of Gravitation</i> |
- 9 Rajah 7 menunjukkan seorang lelaki menukarkan tetapan suhu menggunakan alat kawalan jauh. Selepas beberapa ketika, suhu bilik adalah sama dengan suhu pada alat kawalan jauh itu.  
*Diagram 7 shows a man changing the temperature setting using a remote control. After a while, the room temperature is equal to the temperature on the remote control.*

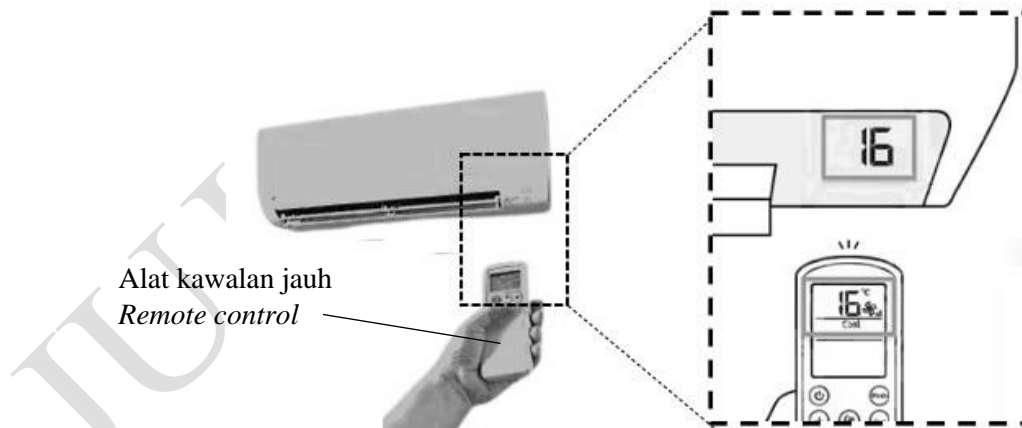

Rajah 7  
 Diagram 7

Konsep manakah yang menerangkan situasi tersebut?  
*Which concept describes the situation?*

- |  |  |
|--|--|
| A Hukum gas<br><i>Gas law</i>                        | C Haba pendam tentu<br><i>Specific latent heat</i> |
| B Muatan haba tentu<br><i>Specific heat capacity</i> | D Keseimbangan terma<br><i>Thermal equilibrium</i> |

- 10 Rajah 8 menunjukkan seorang budak lelaki berpeluh pada waktu tengah hari.  
*Diagram 8 shows a boy sweating at noon.*

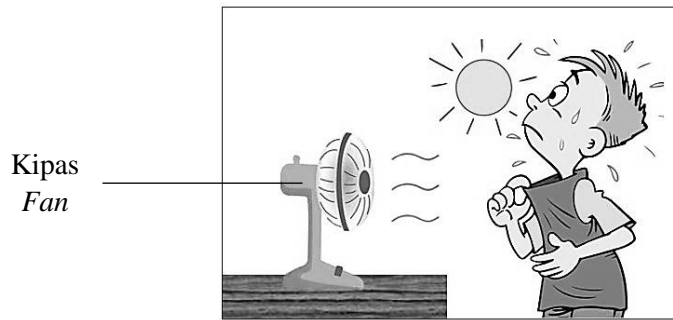

Rajah 8  
*Diagram 8*

Mengapakah budak lelaki itu berasa sejuk apabila kipas dihidupkan?  
*Why does the boy feel cold when the fan is switched on?*

- A Keseimbangan terma berlaku  
*Thermal equilibrium occurs*
- B Kadar penyejatan peluh berkurang dengan adanya aliran udara  
*The rate of sweat evaporation decreases with the presence of air flow*
- C Kadar penyejatan peluh berkurang apabila haba pendam tentu peluh adalah malar  
*The rate of sweat evaporation decreases when the specific latent heat of sweat is constant*
- D Penyejatan peluh yang berlaku menyebabkan haba akan diserap keluar daripada badan  
*Evaporation of sweat occurs causing heat to be absorbed out of the body*
- 11 Rajah 9 menunjukkan pergerakan molekul udara dalam bekas yang dipanaskan bagi suatu molekul udara berjisim tetap.  
*Diagram 9 shows the movement of air molecules in a heated container for a fixed mass of air molecules.*

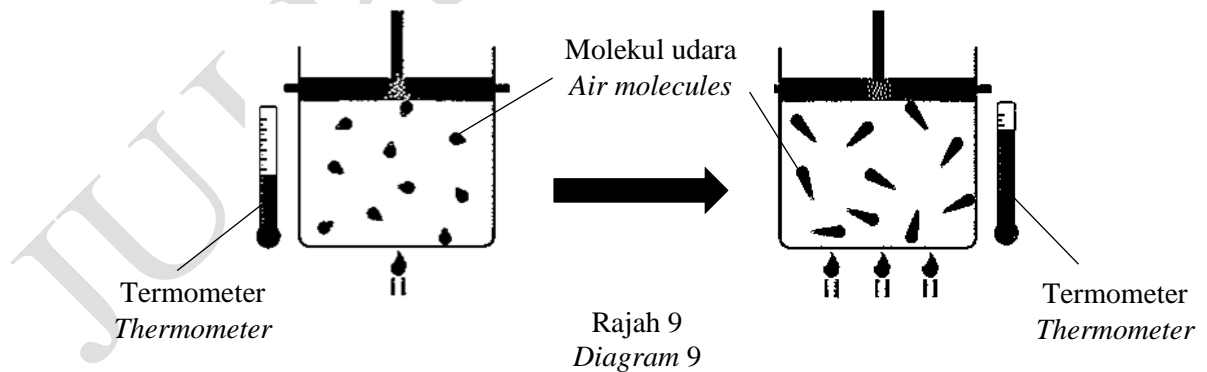

Nyatakan perubahan yang berlaku kepada tekanan bekas.  
*Explain the change that occurs to the pressure of the container.*

- A Tetap  
*Constant*
- B Berubah  
*Changed*
- C Berkurang  
*Decreases*
- D Meningkat  
*Increases*

- 12 Rajah 10 menunjukkan dua tala bunyi yang diletakkan bersebelahan. Bunyi kedengaran apabila tala bunyi S diketuk menggunakan bebola besi dan tala bunyi T juga menghasilkan bunyi yang sama.

*Diagram 10 shows two tuning forks placed next to each other. A sound is heard when a tuning fork S is hit using an iron ball and a tuning fork T also produces the same sound.*

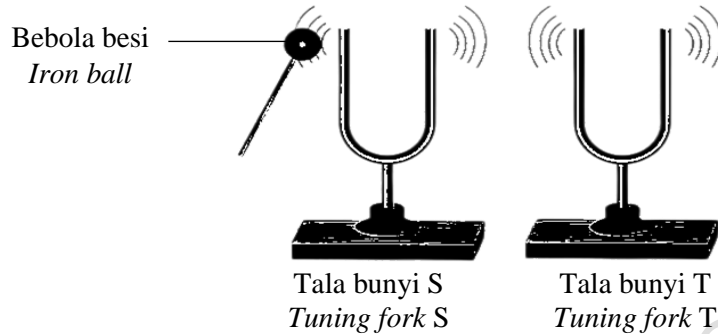

Rajah 10  
Diagram 10

Apakah fenomena yang berlaku?

*What is the phenomenon occurs?*

- |   |   |
|---|---|
| <p><b>A</b> Resonans<br/><i>Resonance</i></p> <p><b>B</b> Pembiasan<br/><i>Refraction</i></p> | <p><b>C</b> Pelembapan<br/><i>Damping</i></p> <p><b>D</b> Pembelauan<br/><i>Diffraction</i></p> |
|---|---|
- 13 Rajah 11 menunjukkan sinar tuju merambat dari medium perspeks ke udara.  
*Diagram 11 shows incident ray propagates from perspex medium to the air.*

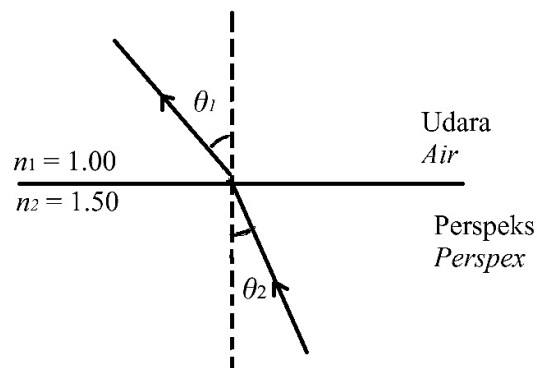

Rajah 11  
Diagram 11

Apakah yang berlaku kepada sudut  $\theta_2$  sekiranya medium tersebut ditukar dengan kaca?

*What happens to the angle  $\theta_2$  if the medium is replaced by glass?*

- |   |  |
|---|--|
| <p><b>A</b> <math>\theta_2 &gt; \theta_1</math></p> <p><b>B</b> <math>\theta_2 &lt; \theta_1</math></p> | <p><b>C</b> <math>\theta_2 = \theta_1</math></p> <p><b>D</b> <math>\theta_2 \neq \theta_1</math></p> |
|---|--|

- 14 Rajah 12 menunjukkan seorang murid yang boleh mendengar bunyi jam loceng melalui dua tiub kadbod yang serupa.  
Diagram 12 shows that a student can hear the sound of alarm clock through two identical cardboard tubes.

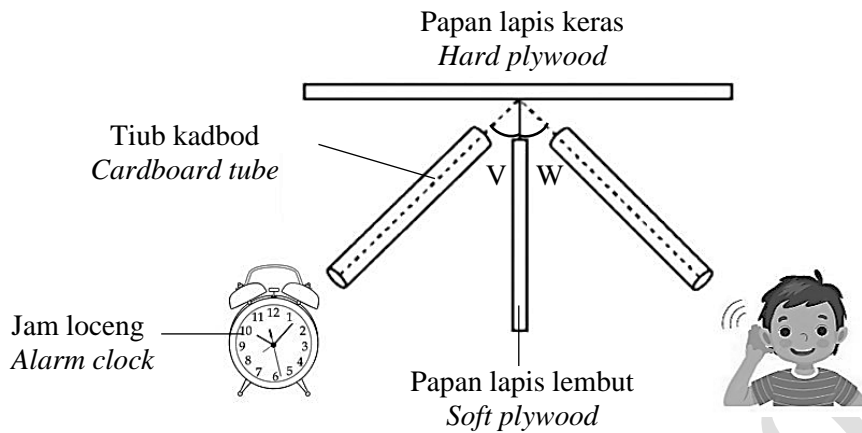

Apakah kuantiti fizik yang diwakili oleh sudut V dan sudut W?  
What are the physical quantities represented by angle of V and angle of W?

	Sudut V Angle of V	Sudut W Angle of W
A	Sudut pantulan Reflected angle	Sudut tuju Incident angle
B	Sudut tuju Incident angle	Sudut pantulan Reflected angle
C	Sudut tuju Incident angle	Sudut biasan Refracted angle
D	Sudut biasan Refracted angle	Sudut tuju Incident angle

- 15 Panjang gelombang bagi cahaya biru di dalam udara ialah 450 nm bergerak pada kelajuan cahaya  $3.00 \times 10^8 \text{ m s}^{-1}$ . Kelajuan cahaya biru berkurangan kepada  $2.15 \times 10^8 \text{ m s}^{-1}$  apabila melalui cecair Z. Berapakah panjang gelombang cahaya biru di dalam cecair Z itu?  
The wavelength of blue light in air is 450 nm traveling at the speed of light  $3.00 \times 10^8 \text{ m s}^{-1}$ . The speed of blue light decreases to  $2.15 \times 10^8 \text{ m s}^{-1}$  when passing through liquid Z. What is the wavelength of blue light in liquid Z?

- A  $1.43 \times 10^{23} \text{ m}$                       C  $3.23 \times 10^{-7} \text{ m}$   
B  $1.95 \times 10^{23} \text{ m}$                       D  $6.28 \times 10^{-7} \text{ m}$

- 16 Rajah 13 menunjukkan panjang gelombang air yang sama merambat melalui suatu celah kecil.  
Diagram 13 shows the same wavelength of water propagating through a small gap.

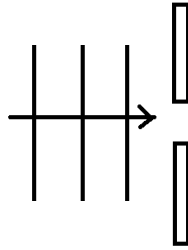

Rajah 12  
Diagram 12

Antara berikut, manakah corak pembelauan gelombang yang betul berdasarkan saiz celah tersebut?  
Which of the following is the correct wave diffraction pattern based on the size of the slit?

Which of the following is the correct wave diffraction pattern based on the size of the slit?

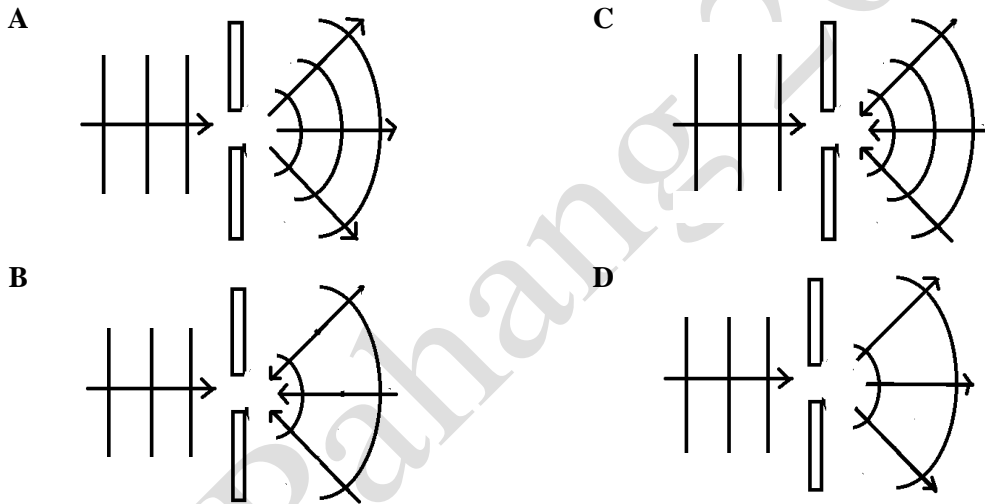

- 17 Rajah 14 di bawah menunjukkan graf  $\frac{1}{v}$  melawan  $\frac{1}{u}$ .

Diagram 14 shows a graph  $\frac{1}{v}$  against  $\frac{1}{u}$ .

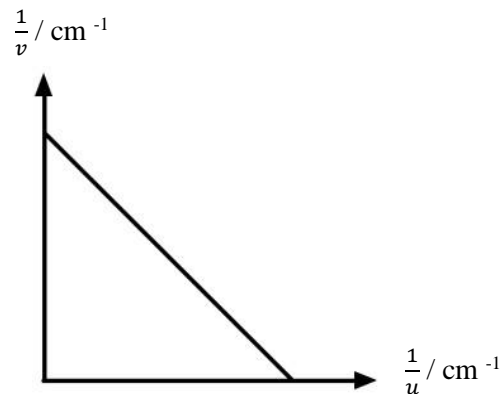

Rajah 14  
Diagram 14

Apakah hubungan antara dua pembolehubah tersebut?

*What is the relationship between the two variables?*

**A**  $\frac{1}{v}$  bertambah dengan  $\frac{1}{u}$   
 $\frac{1}{v}$  increases with  $\frac{1}{u}$

**C**  $\frac{1}{v}$  berkadar songsang dengan  $\frac{1}{u}$   
 $\frac{1}{v}$  inversely proportional to  $\frac{1}{u}$

**B**  $\frac{1}{v}$  berkurang dengan  $\frac{1}{u}$   
 $\frac{1}{v}$  decreases with  $\frac{1}{u}$

**D**  $\frac{1}{v}$  berkurang secara linear dengan  $\frac{1}{u}$   
 $\frac{1}{v}$  decreases linearly to  $\frac{1}{u}$

- 18** Rajah 15 menunjukkan titisan air dalam udara. Apabila cahaya melalui titisan air, ia akan kelihatan seperti berwarna-warni dan ini akan membentuk pelangi.

*Diagram 15 shows water droplets in the air. When the light passes through the water droplets, it will appear as colourful and this will form a rainbow.*

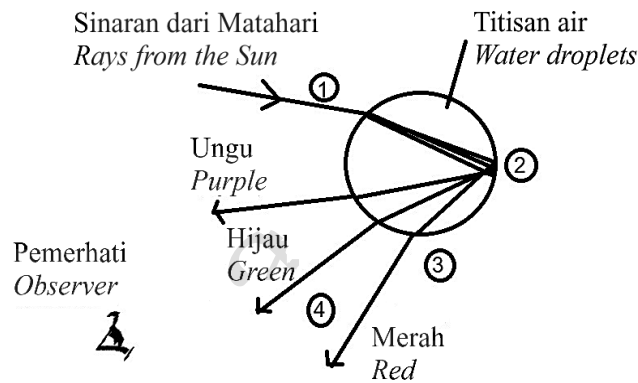

Rajah 15  
 Diagram 15

Manakah antara pernyataan yang berikut yang betul mengenai pembentukan pelangi?

*Which of the following statements is correct about the formation of rainbow?*

- A** Pemerhati melihat warna pelangi berdasarkan pembiasan sahaja  
*Observer sees the colours of the rainbow based on refraction alone*
- B** Sinar-sinar cahaya yang dipantul mengalami penyebaran apabila bergerak dari air ke udara  
*Reflected light rays experience dispersion when travelling from water to air*
- C** Semua warna yang berbeza itu mengalami pantulan dalam penuh pada permukaan dalam dalam titisan air  
*All these different colours experience total internal reflection on the inner surface of the water droplets*
- D** Apabila cahaya putih daripada Matahari memasuki titisan air, cahaya itu mengalami pembiasan dan tersebar kepada warna-warna yang sama  
*When a white light from the Sun enters water droplets, the light experiences refraction and disperses into the same colours*

- 19 Rajah 16 menunjukkan sebuah kanta pembesar.  
*Diagram 16 shows a magnifying glass.*



Rajah 16  
*Diagram 16*

Apakah ciri-ciri imej yang terbentuk sekiranya jika jarak objek semakin besar?  
*What are the characteristics of the image that is formed if the object distance is bigger?*

- |  |  |
|--|--|
| <p><b>A</b> Maya, diperbesar, tegak<br/><i>Virtual, magnified, upright</i></p> <p><b>B</b> Maya, diperkecil, tegak<br/><i>Virtual, diminished, upright</i></p> | <p><b>C</b> Nyata, songsang, diperbesar<br/><i>Real, inverted, magnified</i></p> <p><b>D</b> Nyata, songsang, diperkecil<br/><i>Real, inverted, diminished</i></p> |
|--|--|
- 20 Cermin pergigian merupakan cermin cekung yang digunakan untuk memudahkan pemeriksaan gigi oleh doktor.  
*A dental mirror is a concave mirror which is used to ease the examination of teeth by the doctor.*

Penyataan-pernyataan berikut menerangkan mengenai cermin pergigian.  
*The following statements explain about a dental mirror.*

- I Terbentuk imej yang tegak dan lebih besar dari objek  
*Produced an upright image and larger than object*
- II Semua sinar pantulan akan menumpu pada suatu titik fokus,  $F$   
*All reflected rays will converge at a focal point,  $F$*
- III Merupakan cermin lengkung yang dalamnya dapat memantulkan cahaya  
*It is a curved mirror inside which can reflect light*
- IV Sinar cahaya yang selari mengena suatu cermin cekung, sinar cahaya akan dipantul balik ke arah luar  
*A parallel ray of light hits a concave mirror, the ray of light will be reflected back outwards*

Manakah pernyataan yang betul mengenai cermin pergigian?  
*Which statement is correct about a dental mirror?*

- |   |   |
|---|---|
| <p><b>A</b> I dan II<br/><i>I and II</i></p> <p><b>B</b> I dan III<br/><i>I and III</i></p> | <p><b>C</b> I, II dan III<br/><i>I, II and III</i></p> <p><b>D</b> I, II, III dan IV<br/><i>I, II, III and IV</i></p> |
|---|---|

- 21 Rajah 17 menunjukkan dua daya yang bertindak ke atas satu objek pada arah yang bertentangan.  
*Diagram 17 shows two forces acting on an object in opposite direction.*



Rajah 17  
Diagram 17

Antara pernyataan berikut yang manakah cara yang betul untuk kaedah perhitungan antara dua daya?

*Which of the following statements is the correct way for the method of calculation between two forces?*

- A Arah daya paduan sama dengan magnitud tanpa arah daya  
*The direction of resultant forces is in the magnitude without direction of force*
  - B Arah daya paduan sama dengan arah daya tanpa magnitud  
*The direction of resultant forces is in the direction of force without magnitude*
  - C Daya paduan dinyatakan tanpa memberikan magnitud dan arah  
*The resultant force is expressed without giving magnitude and direction*
  - D Magnitud daya paduan diperoleh daripada hasil tambah vektor dan dua daya  
*Magnitude of the resultant force is obtained from the vector sum of the two forces*
- 22 Rajah 18 menunjukkan sekeping gambar tergantung pegun di dinding dengan tali dan paku. Berat gambar,  $W$  ialah 15.0 N.  
*Diagram 18 shows a picture is hanging stationary on a wall with a string and a nail. The weight of the picture,  $W$  is 15.0 N.*

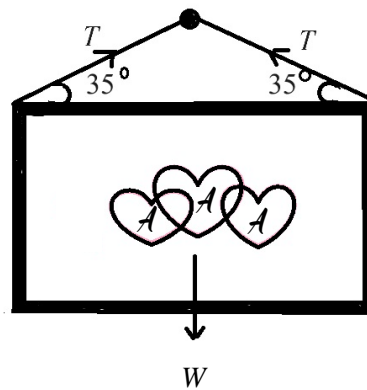

Rajah 18  
Diagram 18

Hitungkan nilai tegangan tali,  $T$ ?

*Calculate the value of tension of string,  $T$ ?*

- A 13.08 N
- B 17.21 N
- C 21.42 N
- D 24.57 N



- 23 Rajah 19 menunjukkan seekor kucing diletakkan tergantung pada empat spring serupa yang disusun secara selari.  
Diagram 19 shows a cat is placed hanging on four identical springs which arranged in parallel.

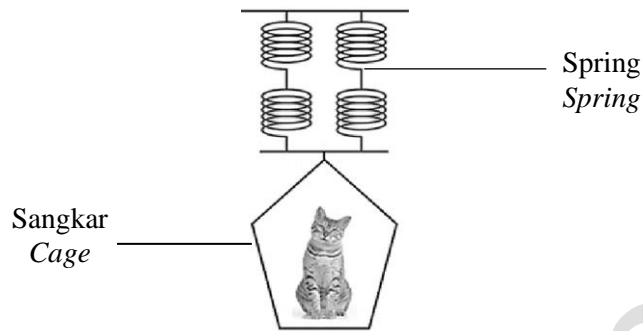

Rajah 19  
Diagram 19

Pernyataan manakah yang betul tentang spring selari?  
Which statement is correct about parallel spring?

- A Tegangan =  $F + 2$   
The tension =  $F + 2$
- B Pemanjangan spring ialah  $2x$   
The extension of spring is  $2x$
- C Pemanjangan spring ialah  $2x + 2x$   
The extension of spring is  $2x + 2x$
- D Pemanjangan sistem spring  $\frac{x}{2}$   
The extension of system of springs  $\frac{x}{2}$
- 24 Rajah 20 menunjukkan sebuah botol yang berisi air.  
Diagram 20 shows a bottle filled with water.

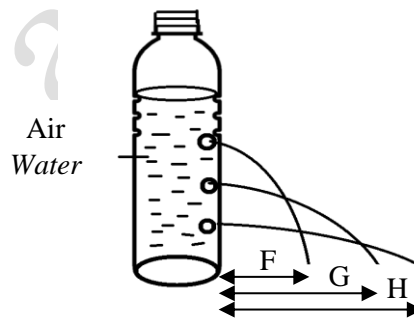

Rajah 20  
Diagram 20

Mengapakah jarak pancutan air berbeza di antara F, G dan H?  
Why is the distance between the water spur out is different between F, G and H?

- A Saiz lubang air yang keluar adalah berbeza  
The size of the water hole that comes out is different
- B Tekanan air bertambah dengan kedalaman  
Water pressure increases with depth
- C Isipadu adalah berbeza mengikut ketinggian lubang air  
The volume is different according to the height of the water hole
- D Ketumpatan air bertambah bagi setiap aras pancutan air  
The density of water increases for each level of the water spur out



- 27 Rajah 23 menunjukkan sistem hidraulik yang menggunakan bendalir untuk memindahkan tekanan.

Diagram 23 shows a hydraulic system that uses a fluid to transmit pressure.

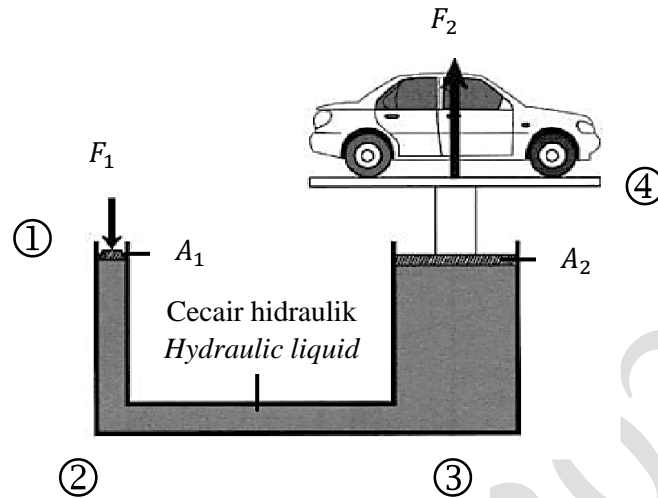

Rajah 23  
Diagram 23

Pernyataan-pernyataan berikut menerangkan prinsip kerja sistem hidraulik.  
The following statements explain the working principle of hydraulic system.

- I Daya input,  $F_1$  dikenakan ke atas omboh input  
Input force,  $F_1$  is applied on the input piston
- II Tekanan dipindahkan secara seragam melalui cecair hidraulik ke omboh output  
Pressure is transmitted uniformly throughout the hydraulic liquid to the output piston
- III Tekanan yang sama bertindak pada permukaan cecair  $A_2$  di omboh output dan daya output,  $F_2$  bertindak ke atas omboh output  
Same pressure acts on the liquid surface  $A_2$  at the output piston and output force,  $F_2$  acts on the output piston
- IV Di omboh input, tekanan  $P_1$  terhasil pada permukaan cecair  $A_1$   
At the input piston, pressure  $P_1$  is produced on the liquid surface  $A_1$

Manakah urutan prinsip kerja yang betul di dalam sistem ini?  
Which is the correct sequence of working principles in this system?

	①	②	③	④
<b>A</b>	I	IV	III	II
<b>B</b>	I	IV	II	III
<b>C</b>	I	III	II	IV
<b>D</b>	I	II	IV	III

28 Manakah antara pernyataan berikut adalah benar mengenai Prinsip Archimedes?  
*Which of the following statements is correct about Archimedes' Principle?*

- A Berat objek di udara adalah berat sebenar objek  
*The weight of object in the air is the actual weight of an object*
- B Daya apungan adalah sama dengan berat sebenar objek  
*The buoyant force is equal to the actual weight of an object*
- C Berat ketara objek adalah sama dengan kehilangan berat ketara  
*The apparent weight of an object is equal to the loss of apparent weight*
- D Isipadu cecair yang disesarkan oleh objek adalah daya apungan objek  
*The volume of liquid displaced by an object is the buoyant force of the object*

29 Rajah 24 menunjukkan nyalaan lilin tersebar kepada dua arah apabila ia diletakkan di ruang antara plat logam bercas, P dan Q.

*Diagram 24 shows a candle flame spread out into two directions when it is placed in the space between charged metal plate, P and Q.*

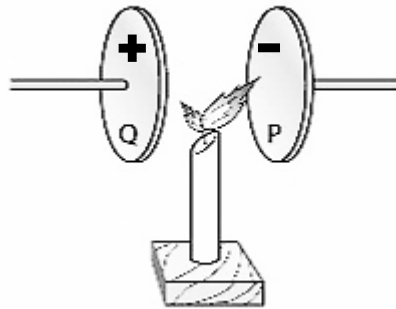

Rajah 24  
Diagram 24

Mengapakah nyalaan lilin lebih banyak tersebar ke plat P berbanding plat Q?

*Why does the candle flame spread more to plate P than to plate Q?*

- A Kekuatan medan elektrik plat P lebih daripada plat Q  
*Strength of electric field P plate more than Q plate*
- B Beza keupayaan antara plat logam bertambah di plat P  
*The potential difference between the metal plates increases at plate P*
- C Ion positif mempunyai jisim dan saiz yang lebih besar berbanding ion negatif  
*Positive ions have a greater mass and size than negative ions*
- D Ion negatif mempunyai jisim dan saiz yang lebih besar berbanding ion positif  
*Negative ions have a greater mass and size than positive ions*

- 30 Rajah 25 menunjukkan lampu tidur yang digunakan selama 6 jam bagi tempoh 30 hari.  
*Diagram 25 shows a sleeping lamp that is used for 6 hours for a period of 30 days.*

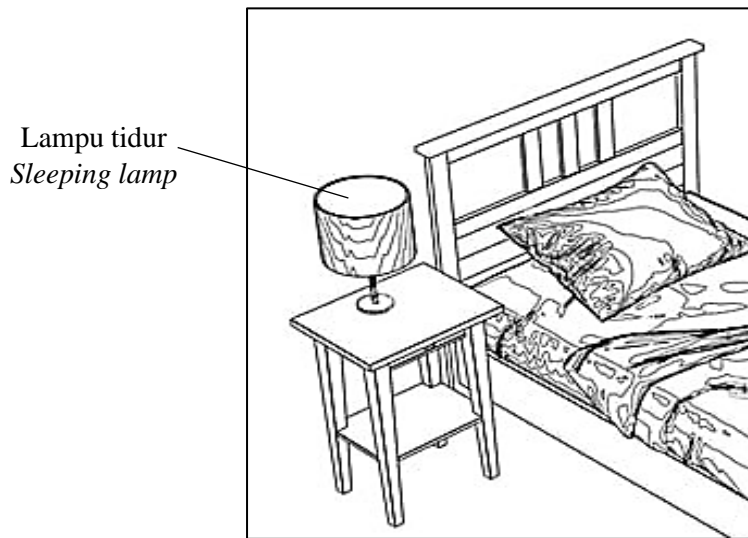

Rajah 25  
*Diagram 25*

Antara berikut, mentol yang manakah sesuai digunakan supaya dapat menghasilkan penjimatan tenaga bagi setiap bulan?

*Which of following bulb is suitable to use in order to produce energy savings for each month?*

**A**



Lampu pijar 60 W  
*Incandescent lamp 60 W*

**C**



Lampu CFL 40 W  
*CFL lamp 40 W*

**B**



Lampu LED 12 W  
*LED lamp 12 W*

**D**



Lampu halogen 40 W  
*Halogen lamp 40 W*

- 31 Rajah 26 menunjukkan litar elektrik untuk menentukan nilai daya gerak elektrik (d.g.e) dan rintangan dalam,  $r$  bagi sel kering.  
 Diagram 26 shows an electric circuit to determine the electromotive force (e.m.f) and internal resistance,  $r$  of a dry cell.

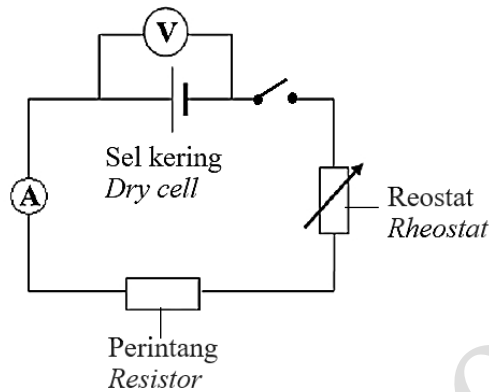

Rajah 26  
 Diagram 26

Apakah nilai yang ditunjukkan oleh bacaan voltmeter pada litar apabila suis dibuka?  
 What is the value that shown on voltmeter reading in circuit when the switch is opened?

- |   |  |   |   |
|---|--|---|---|
| A | Arus litar<br>Current of the circuit   | C | Daya gerak elektrik<br>Electromotive force              |
| B | Rintangan dalam<br>Internal resistance | D | Beza keupayaan litar<br>Potential difference in circuit |
- 32 Rajah 27 menunjukkan gerakan satu dawai kuprum tebal.  
 Diagram 27 shows a motion of a thick copper wire.

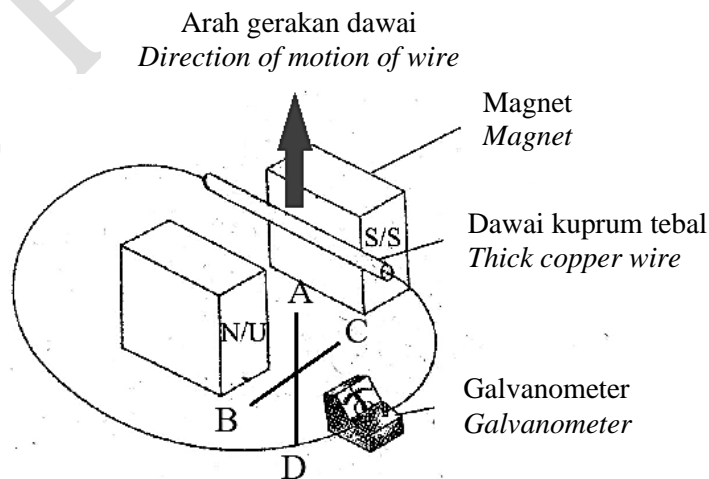

Rajah 27  
 Diagram 27

Antara arah A, B, C dan D, arah manakah pesongan penunjuk galvanometer?  
 At which direction A, B, C and D, is the deflection of galvanometer pointer?

- 33 Rajah 28 menunjukkan gegelung pembawa arus dalam medan magnet.  
 Diagram 28 shows a current-carrying coil in a magnetic field.

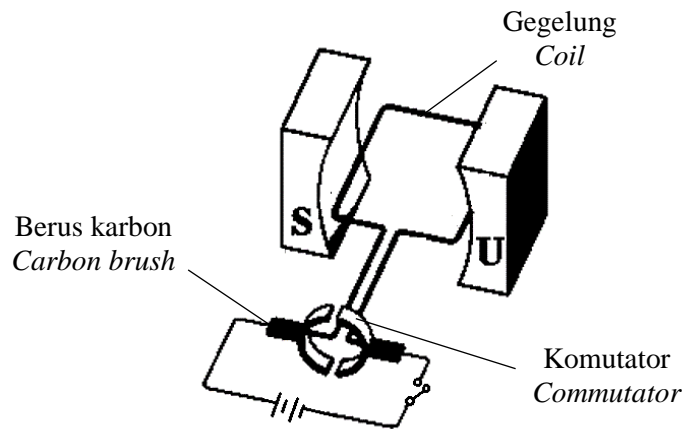

Rajah 28  
 Diagram 28

Rajah manakah yang menunjukkan medan lastik yang betul terbentuk apabila suis ditutup?  
 Which diagram shows the correct catapult field pattern formed when the switch is closed?

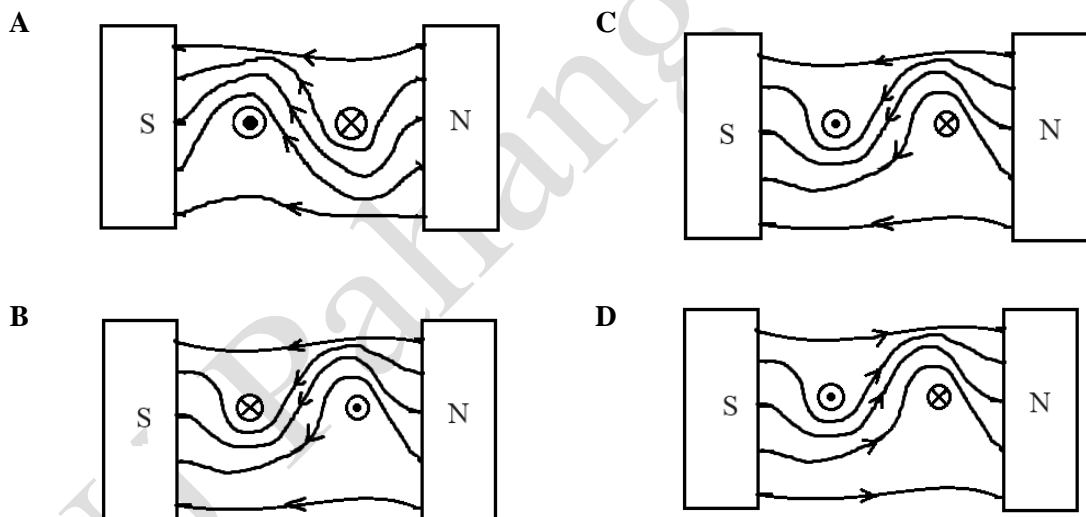

- 34 Rajah 29 menunjukkan satu litar rektifikasi.  
 Diagram 29 shows a rectification circuit.

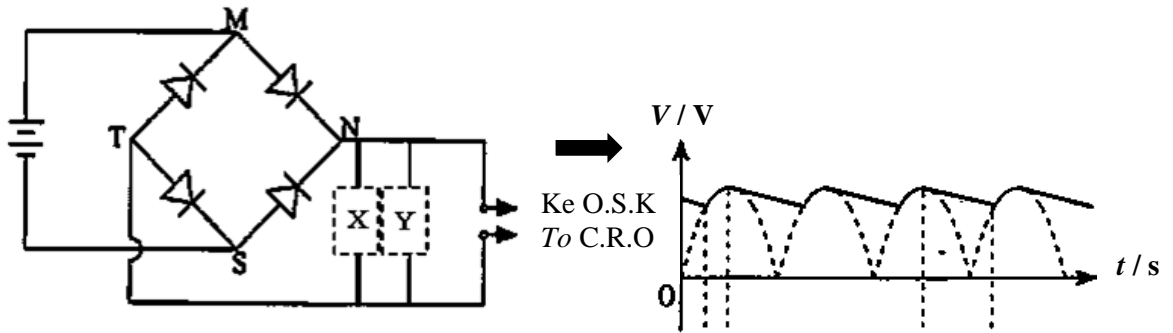

Rajah 29  
 Diagram 29

Pilih pasangan komponen elektronik X dan Y untuk menghasilkan corak O.S.K yang sepadan.  
 Select the pair of electronic components X and Y to produce the corresponding C.R.O pattern.

	Komponen elektronik X Electronic component X	Komponen elektronik Y Electronic component Y
A		
B		
C		
D		



- 35 Rajah 30 menunjukkan katod dipanaskan oleh filamen pemanas.  
Diagram 30 shows the cathode is heated by a heating filament.

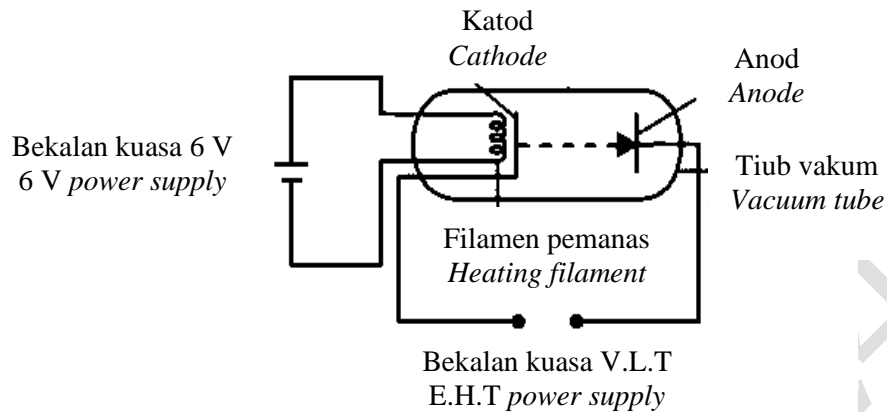

Rajah 30  
Diagram 30

Apakah yang berlaku apabila bekalan kuasa 6 V arus terus, a.t dihidupkan?  
What happens when 6 V direct current, d.c supply is switched on?

- A Sinar katod bergerak dalam garisan lurus  
Cathode ray travels in a straight line
  - B Sinar katod terpesong di dalam medan magnet  
Cathode ray deflected in a magnetic field
  - C Elektron terbebas daripada logam yang dipanaskan  
Electrons are released from heated metal
  - D Sinar katod tidak terpesong di dalam medan elektrik  
Cathode ray cannot be deflected in an electric field
- 36 Rajah 31 menunjukkan suatu litar transistor dengan sebuah termistor dan mentol.  
Diagram 31 shows a transistor circuit with a thermistor and a bulb.

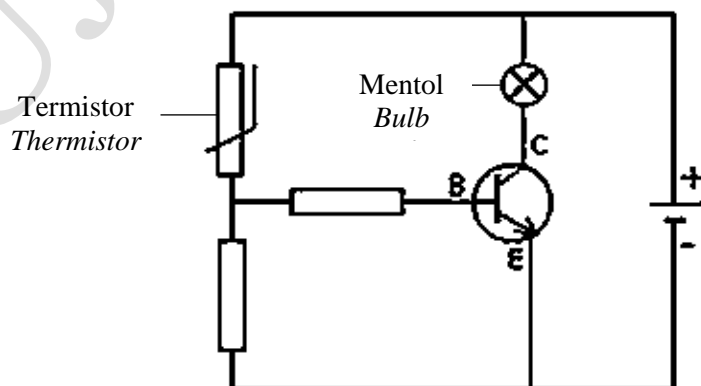

Rajah 31  
Diagram 31

Apakah yang berlaku kepada rintangan termistor dan keadaan mentol itu apabila suhu sekeliling adalah tinggi?

*What happens to the resistance of thermistor and the condition of bulb when the surrounding temperature is high?*

	Rintangan thermistor <i>Resistance of the thermistor</i>	Keadaan mentol <i>Condition of the bulb</i>
<b>A</b>	Rendah <i>Low</i>	Menyala <i>Light up</i>
<b>B</b>	Rendah <i>Low</i>	Tidak menyala <i>Does not light up</i>
<b>C</b>	Tinggi <i>High</i>	Menyala <i>Light up</i>
<b>D</b>	Tinggi <i>High</i>	Tidak menyala <i>Does not light up</i>

- 37** Rajah 32 menunjukkan reaktor nuklear.  
*Diagram 32 shows a nuclear reactor.*

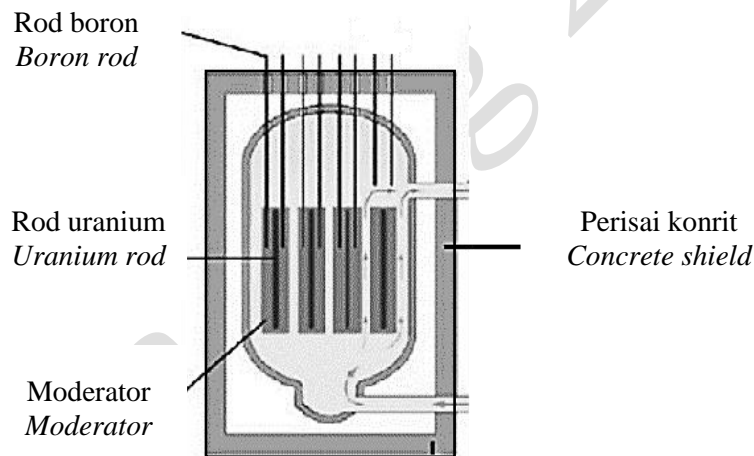

Rajah 32  
*Diagram 32*

Apakah fungsi rod pengawal?  
*What is the function of control rod?*

- A** Menurunkan suhu reaktor  
*Lower the temperature of reactor*
- B** Memperlahankan kelajuan neutron  
*Slower the speed of neutron*
- C** Menyerap neutron yang berlebihan  
*Absorb the excessive neutron*
- D** Menghalang kebocoran sinar radioaktif  
*Avoid the leakage of radioactive ray*



- 40 Rajah 33 menunjukkan graf tenaga kinetik maksimum,  $K_{maks}$  fotoelektron melawan frekuensi,  $f$  cahaya bagi dua jenis logam yang berbeza, M dan N.  
*Diagram 33 shows a graph of maximum kinetic energy of photoelectron,  $K_{max}$  against frequency,  $f$  of light for two different types of metals, M dan N.*

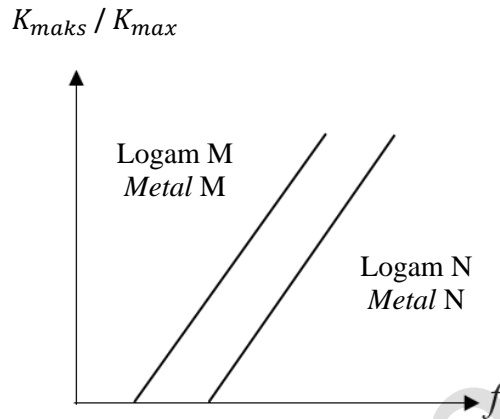

Rajah 33  
Diagram 33

Berdasarkan graf, pernyataan manakah adalah betul?  
*Based on the graph, which of the following statement is correct?*

- A Kecerunan graf mewakili pemalar Planck  
*The gradient of graph represents Planck's constant*
- B Logam yang berbeza mempunyai frekuensi ambang yang sama  
*Different metals have same threshold frequencies*
- C Fungsi kerja logam M adalah lebih tinggi daripada fungsi kerja logam N  
*The work function of metal M is higher than the work function of metal N*
- D Frekuensi ambang logam M adalah lebih tinggi daripada frekuensi ambang logam N  
*The threshold frequency of metal M is higher than the threshold frequency of metal N*

**KERTAS SOALAN TAMAT**  
**END OF QUESTION PAPER**